

HOW TO ORDER SERVICES

Our recommendation

- take notes of deadlines for particular services
- use our on-line ordering system on <http://b2b.triumfexhibitions.cz/>
- or you can send your orders by e-mail :

TRIUMF EXHIBITIONS CZ, s.r.o. – Official Exhibition Management

Mrs. Zdena Fialová

Vodnická 48

147 00 Praha 4

Czech Republic

e-mail: zdena.fialova@triumfexhibitions.cz, zdena.fialova@seznam.cz

mobil: +420 777 570 844

LATE ORDERS, ON-SITE ORDERS

Orders made after the deadline cannot be guaranteed.

Late orders received after deadlines or during the set-up period will be fulfilled in accordance with time and capacity and will be subjected to the following surcharges:

+10% if orders are received after September 17, 2021

+ 50% if orders are received after October 20, 2021

The date of the surcharge is the date the order is received by the Triumf Exhibitions cz.

As stated in the General Conditions, if the exhibitor fails to cover all the fees related to participation at the congress as well as all other outstanding payments to Triumf Exhibitions, no work will be done. No exceptions from these rules will be made.

On-Site Orders

Services ordered during the set-up period, exhibition itself or when the event is over, will be provided only according to the availability of the respective work persons and/or materials. The exhibitor will be asked to make complete payment for required services in advance. Only then the service will be provided. No copies of payment confirmations or similar documents will be accepted. Actualisation of requirements made after the deadline and on-site orders can take longer than normal orders.

We therefore recommend to place all orders in time.

Payment Conditions

After receiving orders Triumf Exhibitions cz will send an invoice to the exhibitor and it must be paid through a bank in time. On-site payments can be made in cash or by a credit card.

For payments in cash, CZK or EUR currency will be accepted. For payments by a credit card, Triumph Exhibitions cz accepts Visa, Eurocard-Mastercard, Amex and Diner Club. Cheques are not accepted.

Claims

Claims can be made only by the end of the event. Claims must be made in writing and will only be accepted at the Exhibition Management desk. Claims submitted later will not be taken into consideration.

LIST OF DEADLINES

Please use this form to keep an easy record of orders you have completed and sent, as those you still intend to send.

Please adhere the deadlines indicated below.

REQUIRED SERVICES	DEADLINE	SENT ON
Stand Construction	September 17, 2021	
Stand Equipment	September 17, 2021	
Text and graphics	September 17, 2021	
Schematic Plan	September 17, 2021	
Power Supply	September 17, 2021	
Carpet	September 17, 2021	
Cleaning	September 17, 2021	
Audio/Video/PC/Internet	September 17, 2021	
Hostesses	September 17, 2021	
Floral decoration	September 17, 2021	

STAND CONSTRUCTION ORDER

Exhibitor:	Stand No.:
Contact person:	
Invoice address:	
Telephone:	Fax:
E-mail:	VAT-ID number:

The Shell Scheme does not include any technical connections. Do not forget to order power connection. 3,5 kW connection is recommended, please see form Power Supply.

The space can be filled with other items which can be ordered separately. For furniture please see form Stand Equipment.

If you require a Custom-made stand we can prepare a project and estimated price according to your specific requirements or we are also able to construct the stand according to your own project.

PRICE LIST:

specification	price Euro/m ²	m ²	total Euro
Octanorm without furniture	68		
Octanorm with furniture	76		
Modular Stand A	90		
Modular Stand B	96		
Modular Stand C1	110		
Modular Stand C2	115		
Modular Stand D	120		

The prices do not include 21% VAT.

The total price covers, among other items, your company name sign. Your company name will be executed in black lettering in the HELVETICA font. The total length of the name is restricted to 18 letters.

REQUIRED NAME:

--	--	--	--	--	--	--	--	--	--	--	--	--	--	--	--	--	--

.....
Stamp & Authorised Signature

.....
Date & Place

Please return this form to:

Triumpf Exhibitions cz, Vodnická 48/437, 147 00 Praha 4
 Tel.: +420/274 818 065, Fax: +420/274 772 406, mobil: +420/777570844
 e-mail: zdena.fialova@triumfexhibitions.cz, zdena.fialova@seznam.cz

OCTANORM STANDS



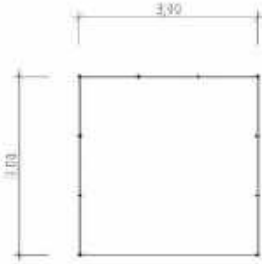



OCTANORM STAND without furniture

size: from 9 m²

equipment:

1. rear and side walls
2. ceiling with spotlights
3. light grey carpet





OCTANORM STAND with furniture

size: from 9 m²

equipment:

1. rear and side walls
2. ceiling with spotlights
3. light grey carpet
4. table 80x80 cm
5. 3x chair
6. infodesk

MODULAR STANDS



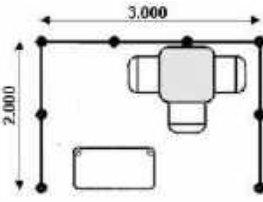

MODULAR STAND A

size: from 6 m²

equipment:

1. rear and side walls
2. ceiling with spotlights
3. light grey carpet
4. table 70x70 cm
5. 3x chair
6. infodesk
7. fascia with the company name



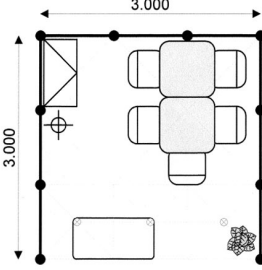

MODULAR STAND B

size: from 9 m²

equipment:

1. rear and side walls
2. ceiling with spotlights
3. light grey carpet
4. 2x table 70x70 cm
5. 5x chair
6. lockable cabinet
8. coat rack
9. infodesk

MODULAR STANDS

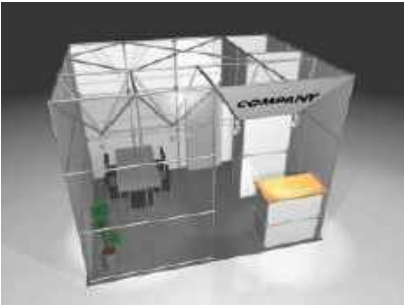
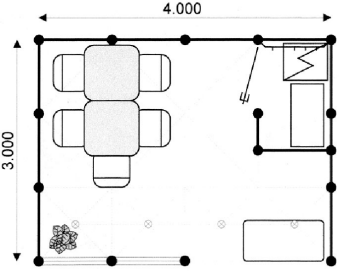



MODULAR STAND C

size: **from 12m²**

equipment:

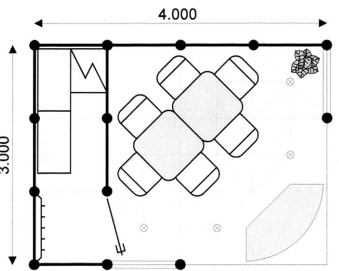
1. rear and side walls with storage
2. glass front wall
3. ceiling with spot lights
4. light grey carpet
5. 2x table 70x70 cm
6. 5x chair
7. shelf
8. refrigerator
9. wall coat rack set
10. infodesk
11. flower





MODULAR STAND C2

size: **from 12m²**

equipment:

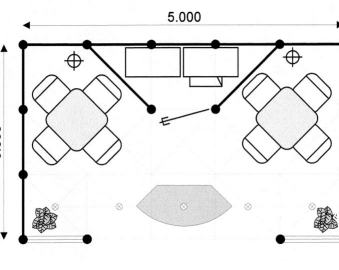
1. rear and side walls with storage
2. glass front wall
3. ceiling with spotlights
4. light grey carpet
5. 2x table 70x70 cm
6. 6x chair
7. 2x shelf
8. refrigerator
9. wall coat rack set
10. infodesk

MODULAR STAND D

size: **from 15m²**

equipment:

1. rear and side walls with storage
2. glass front wall
3. ceiling with spotlights
4. light grey carpet
5. 2x table 70x70 cm
6. 8x chair
7. 2x shelf
8. refrigerator
9. 2x wall coat rack set
10. infodesk
11. 2x flower

STAND EQUIPMENT

Exhibitor:	Stand No.:
Contact person:	
Invoice address:	
Telephone:	Fax:
E-mail:	VAT-ID number:

Specification	lxdxh cm	picture No.	pieces	unit price Euro	total price
Spotlight 100W				22	
Halogen spotlight 500W				59	
3-prong plug 220V				15	
Refrigerator	80x80x100	46		103	
Octanorm coat rack set	length 100			12	
High illuminated showcase, 4x halogen 50W	100x100x250	4		138	
High illuminated showcase, 2x halogen 50W	100x50x250	4		114	
Octanorm glass counter	100x100x100	5		67	
Octanorm glass counter	100x50x100	5		52	
Octanorm counter	100x100x100	3		47	
Octanorm counter with shelf, wooden top	100x100x100	1		54	
Octanorm counter	50x50x100	3		35	
Octanorm counter with shelf, wooden top	50x50x100	1		40	
Octanorm counter	100x50x100	3		45	
Octanorm counter with shelf, wooden top	100x50x100	1		52	
Octanorm bar counter	100x100x110	3		60	
Octanorm bar counter with shelf, wooden top	100x100x110	1		70	
Octanorm bar counter	100x50x110	3		55	
Octanorm bar counter with shelf, wooden top	100x50x110	1		65	
Octanorm bar counter	50x50x110	3		40	

Specification	lxdxh cm	picture No.	pieces	unit price Euro	total price
Octanorm bar counter with shelf, wooden top	50x50x110	1		48	
Octanorm semicircular counter	100x50x100	2A		75	
Octanorm semicircular counter, wooden top	100x50x100	2		79	
Octanorm shelf stand	100x50x250			45	
Book shelf panel	100x30			18	
Chair black		25		17	
Chair plastic dark grey		19		60	
Chair Gilber		20		44	
Chair chrom black		22		19	
Chair design white*		23		62	
Leather chair (anthracite, black or white)*		24		60	
Leather bar chair white		27		40	
Leather bar chair black		28		28	
White bar chair		29		32	
Plastic bar chairs (black, silver, white)*		30		40	
Wooden bar chair*		26		60	
Chair with wheels white or blue		21		19	
Table	80x80	14		21	
Table with blue skirting	150x60x80	18		39	
Round table black or white*	80	7		23	
Round table wooden top	80	9		23	
Small table black or white*	50x50x45	11		20	
White table	90 x55x45	16		35	
Buffet table glass*	110x60	13		120	
Small round glass table*	60x45	15		85	
Round glass table*	105x73	17		90	
Buffet table glass*	110x60	13		120	
Buffet table wooden top	60x110	9		42	
Buffet table black top	60x105	8		42	
Buffet table white top	60x105	12		42	
Buffet table chrome	60x105	10		42	
Black leather armchair*		31		160	

Specification	lxdxh cm	picture No.	pieces	unit price Euro	total price
Natural color armchair*		32		80	
Small black armchair		33		66	
Sofa red, white, black, blue *	180x88x69/54	42		270	
Tabouret blue, red, white	54x54x39	43		49	
Sofa leather black and white	177x90x65/40	44,45		290	
Lockable cabinet	100x50x80	6		45	
Coat hanger stand		48		15	
Waste basket				9	
Stand for brochures type A		50		39	
Stand for brochures type B		51		50	
Stand for brochures*		49		60	
Pole with siling belt 2,3m		45		42	
Pole with a holder*		47		30	

* a limited number of items

The prices do not include 21% VAT.

.....
Stamp & Authorized Signature

.....
Date & Place

Please return this form to:

Triumf Exhibitions cz, Vodnická 48, 147 00 Praha 4
Tel.: +420/274 818 065, Fax: +420/274 772 406, mobil: +420/777570844
e-mail: zdena.fialova@triumfexhibitions.cz, zdena.fialova@seznam.cz

1. Counter wooden top



dimensions: 100 x 50 x 100 cm
other option: 100 x 100 x 100 cm
50 x 50 x 100 cm
50 x 50 x 80 cm

Also as a bar counter:
100 x 50 x 110 cm
other option: 100 x 100 x 110 cm
50 x 50 x 110 cm

2. Semicircular counter wooden top



dimensions: 100 x 50 x 100 cm
also with white top (2A)



3. White counter



dimensions: 100 x 50 x 100 cm
other option: 100 x 100 x 100 cm
100 x 50 x 110 cm

4. High illuminated showcase (2 x halogen 50W)



dimensions: 100 x 50 x 250 cm
other option: 100 x 100 x 250 cm

5. Glass counter (glass top)



dimensions: 100 x 50 x 100 cm
other option: 100 x 100 x 100 cm

6. Lockable cabinet white



dimensions: 100 x 50 x 80 cm

7. Round table white

dimensions: 80 x 75 cm
 other option: black 80 x 75 cm



8. Buffet table black

dimensions: 60 x 105 cm



9. Round table chrome - wooden top

dimensions: 80 x 75 cm
 also as buffet table (9A)
 dimensions: 60 x 105 cm



10. Buffet table chrome

dimensions: 60 x 105 cm



11. Table white - jack

dimensions: 55 x 55 x 45 cm
 also in black (11A)



12. Buffet table white

dimensions: 60 x 105 cm



13. Round glass table

dimensions: 60 x 110 cm



14. Square table glass

dimensions: 80 x 80 cm



15. Round table glass top

dimensions: 60 x 45 cm



16. Table white

dimensions: 90 x 55 x 45 cm



17. Round table glass

dimensions: 105 x 73 cm



18. Table with blue skirting 150 x 60 x 80 cm



19. Plastic chair dark grey



20. White chair Gilbert



21. White chair



22. Chair chrome / black



23. Chair design white



24. Chair leather anthracite black or white



25. Black chair



#

Triumf Exhibitions CZ

CHAIRS, BAR CHAIRS

26. Wooden bar chair



27. Black design bar chair



28. Black bar chair



29. White bar chair



30. Plastic bar chairs 40 x 86 cm - black.(30A) / silver. (30B) / white (30C)



31. Black leather armchair

dimensions: 73 x 75 x 75-46 cm



32. Natural color armchair

dimensions: 80 x 72 x 78-46 cm



33. Small black armchair



42. Sofa 180 x 88x69/54 cm - red (42A) / blue (42B) / white (42C)



43. Tabouret 54 x 54 x 39 cm - blue (43A) / red (43B) / white (43C)



44. Sofa leather 177x90x65/40 cm - black



45. Sofa leather 177x90x65/40 cm - white



45. Poles with sliding belts 2,3 m



46. Refrigerator 80 x 80 x 100 cm



47. Pole with a holder



48. Clothes hanger



49. Stand for brochures



50. Stand for brochures A



51. Stand for brochures B



TEXT & GRAPHICS

Exhibitor:	Stand No.:
Contact person:	
Invoice address:	
Telephone:	Fax:
E-mail:	VAT-ID number:

Name	price Euro	pc.	total price
Logo on a counter 80 cm wide	110		
Logo on a fascia 25 cm high	95		
Poster full colour 90x100 cm on system wall	125		
Poster full colour W95 x H225,5 cm on system wall	210		

The prices do not include 21% VAT.

Please, send us your logo or poster by e-mail in pdf or cdr format.

In case you wish to have other signage, please write below your requirements including the dimensions, material etc. On the basis of this specification we will work out price quotation and present it for approval.

.....
Stamp & Authorized Signature

.....
Date & Place

Please return this form to:

Triumf Exhibitions cz, Vodnická 48, 147 00 Praha 4
 Tel.: +420/274 818 065, Fax: +420/274 772 406, mobil: +420/777570844
 e-mail: zdena.fialova@triumfexhibitions.cz, zdena.fialova@seznam.cz

SCHEMATIC PLAN

Exhibitor:	Stand No.:
Contact person:	
Invoice address:	
Telephone:	Fax:
E-mail:	VAT-ID number:

1. Sketch the location of your utilities, such as furniture, power outlets, spotlights and water, on the plan below. Do not forget to mark on this Schematic Plan the border of your stand, as well as the orientation of your drawing (to clarify where there is a passage and where a neighboring stand is).

2. If the schematic plan is not returned, then the ordered items will be placed at the discretion of Triumph Exhibitions and any relocation will be at the Exhibitor's expense.

PLEASE INDICATE DIMENSIONS OF YOUR BOOTH
GRID FOR SCHEMATIC PLAN:

⚡ electric supply
Ⓢ spotlight

Your company name will be executed in standard lettering in the HELVETICA font. The total length of the name is restricted to 20 letters.

--	--	--	--	--	--	--	--	--	--	--	--	--	--	--	--	--	--	--	--

.....
 Stamp & Authorised Signature

.....
 Date & Place

Please return this form to: zdena.fialova@triumfexhibitions.cz

POWER SUPPLY

Exhibitor:	Stand No.:
Contact person:	
Invoice address:	
Telephone:	Fax:
E-mail:	VAT-ID number:

PRICE LIST:

Specification	price/pc/EUR
Connection up to 3,5 kW/16A	257
Connection up to 7,0kW/2x16A	379
Connection up to 10,5kW/3x16A	485
Connection up to 21kW/3x32A	875
Electrical inspection	49
24-hour connection for refrigerator	225

The prices do not include 21% VAT.

REQUIREMENTS:

Specification	number	total price
Connection up to 3,5 kW/16A		
Connection up to 7,0 kW/16A		
Connection up to 10.5/3x16A		
Connection up to 21 kW/3x32A		
Electrical inspection	1	49
24-hour connection for refrigerator		
Total		

.....
Stamp & Authorised Signature

.....
Date & Place

Please return this form to:

Triumf Exhibitions cz, Vodnická 48, 147 00 Praha 4
 Tel.: +420/274 818 065, Fax: +420/274 772 406, mobil: +420/777570844
 e-mail: zdena.fialova@triumfexhibitions.cz, zdena.fialova@seznam.cz

CARPETING

Exhibitor:	Stand No.:
Contact person:	
Invoice address:	
Telephone:	Fax:
E-mail:	VAT-ID number:

This form is intended for space exhibitors only.

REQUIREMENTS:

Specification	space (m ²)	price per m ²	total price
Carpet		Euro 22	
Required colour	<i>light grey</i> <input type="checkbox"/>	<i>dark grey</i> <input type="checkbox"/>	<i>green</i> <input type="checkbox"/>
		<i>red</i> <input type="checkbox"/>	<i>blue</i> <input type="checkbox"/>

The prices do not include 21% VAT.

.....
Stamp & Authorised Signature

.....
Date & Place

Please return this form to:

Triumf Exhibitions cz, Vodnická 48, 147 00 Praha 4
 Tel.: +420/274 818 065, Fax: +420/274 772 406, mobil: +420/777570844
 e-mail: zdena.fialova@triumfexhibitions.cz, zdena.fialova@seznam.cz

CLEANING

Exhibitor:	Stand No.:
Contact person:	
Invoice address:	
Telephone:	Fax:
E-mail:	VAT-ID number:

Cleaning Includes: general cleaning before opening of the event, daily cleaning of carpeting with vacuum cleaner, waste disposal, washing of furniture. Cleaning will be done mainly at night, when the exhibition halls are closed. Listed prices are for the entire exhibition time.

REQUIREMENTS:

Specification	space m ²	price per m ²	total price
Stand cleaning		Euro 8	

The prices do not include 21% VAT.

.....
Stamp & Authorised Signature

.....
Date & Place

Please return this form to:

Triumf Exhibitions cz, Vodnická 48, 147 00 Praha 4
Tel.: +420/274 818 065, Fax: +420/274 772 406, mobil: +420/777570844
e-mail: zdena.fialova@triumfexhibitions.cz, zdena.fialova@seznam.cz

AUDIO/VIDEO/PC/INTERNET

Exhibitor:	Stand No.:
Contact person:	
Invoice address:	
Telephone:	Fax:
E-mail:	VAT-ID number:

PRICE LIST:

Specification	Price per item	Required number	Price total
LCD 22" Full HD, HDMI, VGA	Euro 60		
LCD 24" Full HD, HDMI, VGA	Euro 75		
LCD 32" Full HD, HDMI, USB	Euro 120		
LCD 42" with floor-stand, Full HD, HDMI, USB	Euro 170		
LCD 50" with floor-stand, Full HD, HDMI, USB	Euro 220		
LCD 55" with floor stand, UHD, HDMI, USB	Euro 240		
LCD 65" with float stand, Full HD, HDMI, USB	Euro 480		
LCD 75", Full HD, HDMI, USB	Euro 590		
LCD 55" Touch screen, Full HD, HDMI, VGA	Euro 690		
Notebook	Euro 150		
Internet – 10Mb/s (cable connection)	Euro 320		
Internet – 20Mb/s (cable connection)	Euro 480		
Internet – 50Mb/s (cable connection)	Euro 750		
Internet – WIFI FOR 40 people	Euro 480		

The prices do not include 21% VAT

If you require any other equipment please contact directly:

zdena.fialova@triumfexhibitions.cz

All the listed prices are for the entire exhibition time. When the exhibition is over, the equipment will be collected from expositions.

.....
Stamp & Authorised Signature

.....
Date & Place

Please return this form to:

Triumf Exhibitions cz, Vodnická 48, 147 00 Praha 4

Tel.: +420/274 818 065, Fax: +420/274 772 406, mobil: +420/777570844

e-mail: zdena.fialova@triumfexhibitions.cz, zdena.fialova@seznam.cz

HOSTESSES

Exhibitor:	Stand No.:
Contact person:	
Invoice address:	
Telephone:	Fax:
E-mail:	VAT-ID number:

PRICES LIST:

Specification

price per hour/Euro

Hostess with knowledge of English (3 hours per day minimum)	15
Briefing of a hostess (120 minutes maximum)	18

The prices do not include 21% VAT.

Hostesses are dressed in a white shirt and a black skirt. If you require a hostess dressed in clothes with your company colors, please contact zdena.fialova@triumf-expo.cz and we will prepare for you a price quotation according to your requests.

REQUIREMENTS:

Date	No.	from	to	hours	price
October 23, 2021					
October 24, 2021					
October 25, 2021					
TOTAL					

Stamp & Authorized Signature

Date & Place

Please return this form to:

Triumf Exhibitions cz, Vodnická 48, 147 00 Praha 4

Tel.: +420/274 818 065, Fax: +420/274 772 406, mobil: +420/777570844

e-mail: zdena.fialova@triumfexhibitions.cz, zdena.fialova@seznam.cz

FLORAL DECORATION

Exhibitor:	Stand No.:
Contact person:	
Invoice address:	
Telephone:	Fax:
E-mail:	VAT-ID number:

Name	Picture No.	price Euro	pc.	total price
<i>Plants 150 – 180 cm</i>				
Ficus Benjamina	56	30		
Kentia (palm)	54	52		
Schefflera	55	48		
Dracaena Marginata		48		
<i>Plants 100 – 120 cm</i>				
Ficus Benjamina	56	25		
Schefflera	55	30		
<i>Ikebana</i>				
small	50A	35		
medium	52	48		
large		59		

The prices do not include 21% VAT.

.....
Stamp & Authorized Signature

.....
Date & Place

Please return this form to:

Triumf Exhibitions cz, Vodnická 48, 147 00 Praha 4
 Tel.: +420/274 818 065, Fax: +420/274 772 406, mobil: +420/777570844
 e-mail: zdena.fialova@triumfexhibitions.cz, zdena.fialova@seznam.cz

50. Ikebana small



A



B

51. Ikebana medium



52. Ikebana medium



54. Kentia



55. Schefflera



56. Ficus benjamina



57. Dracena marginata

